

KTM TECHNICAL BULLETIN

December 4, 2001



TB 0230

Racing Four Stroke Valve Clearance, All Models and All Years.

The valve clearance for the KTM Racing Four Stroke, all model 400/520 and all model years, is 0.12mm for both intake and exhaust valves.

You may find different valve clearances listed in some KTM Information (i.e., Owner's Handbook, Engine Parts Book, KTM Shop Repair Manual, etc.,) and also describing "loose" and "tight" feeler gauge setting methods for achieving these results but the precise setting clearance is 0.12mm (A ill. # 1).

The "light" and "does not insert" setting methods described in some information should not be used and it is always recommended to use the correct thickness feeler gauge of 0.12mm (.0047 inch) when setting valve clearance on the KTM Racing Four Stroke.

Illustration #1, A = 0.12 mm

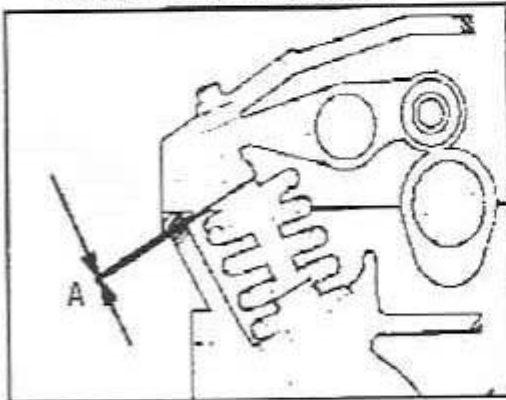

Torque lock nut to 8 ft/lbs / 11 Nm

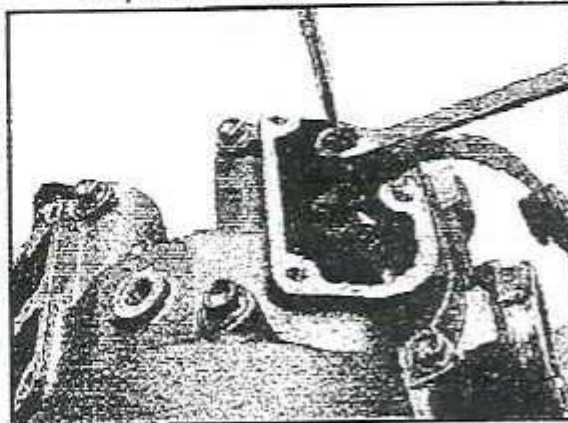

Specifications subject to change without notification.

Not a warranty item.

KTM SPORTMOTORCYCLE USA, INC.
Technical Department